

REFERENCE SEASTROM WORKMANSHIP STD. 8.4.1.W2

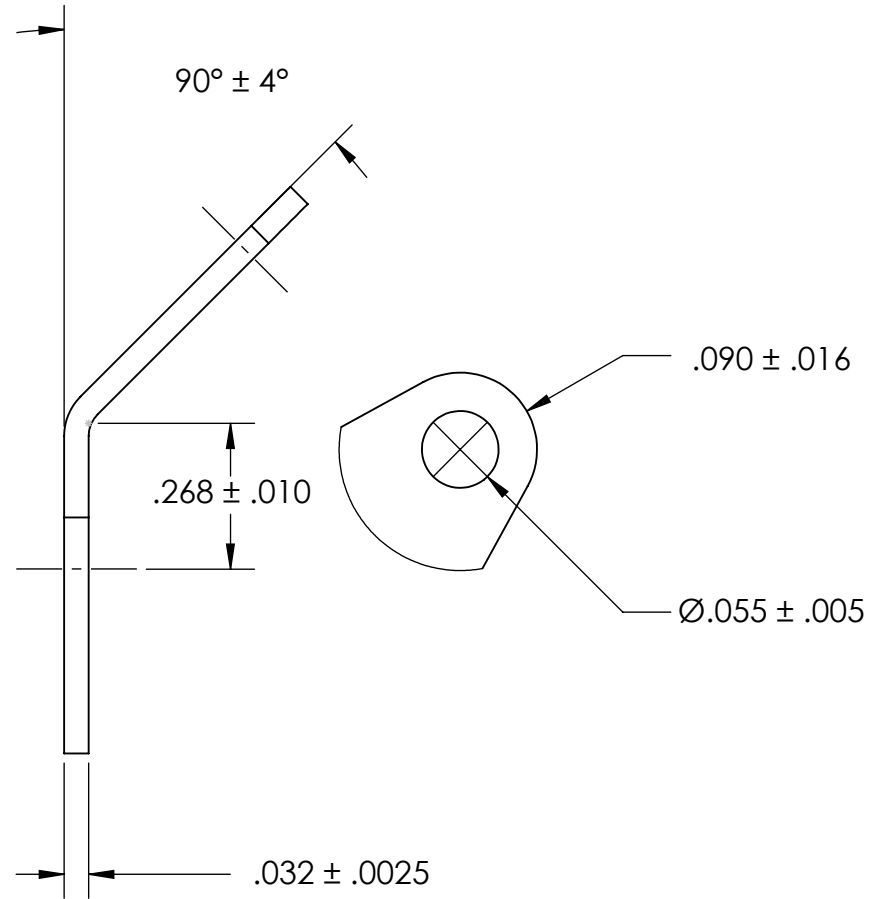
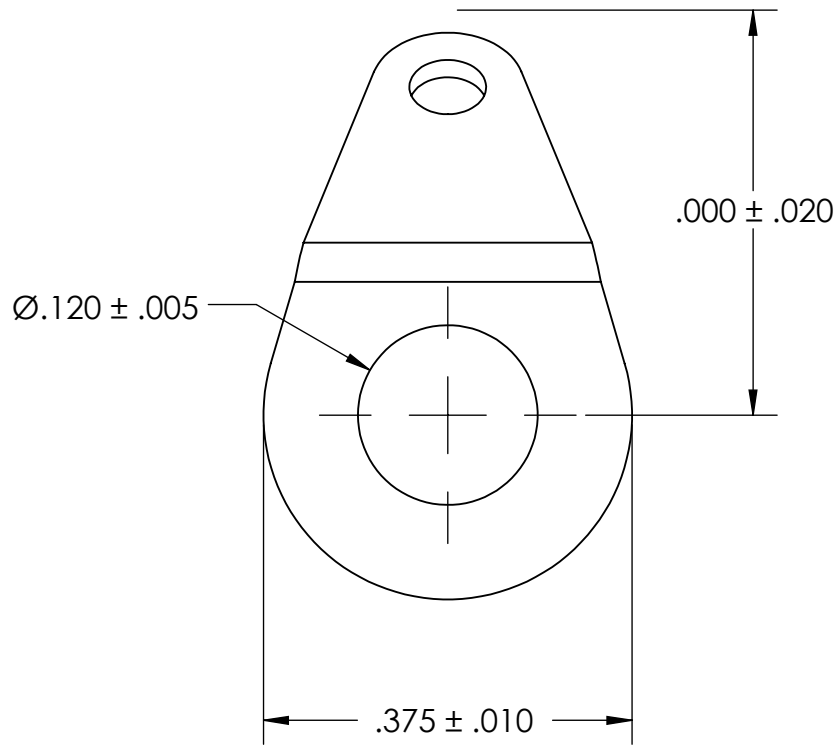

NOTES:  
1. NONE

**PROPRIETARY AND CONFIDENTIAL**  
THE INFORMATION CONTAINED IN THIS DRAWING IS THE SOLE PROPERTY OF SEASTROM MANUFACTURING. ANY REPRODUCTION IN PART OR AS A WHOLE WITHOUT THE WRITTEN PERMISSION OF SEASTROM MANUFACTURING IS PROHIBITED.

DIMENSIONS ARE IN INCHES TOLERANCES: FRACTIONAL $\pm 1/32$ ANGULAR: MACH $\pm 1/2$ Deg TWO PLACE DECIMAL $\pm .01$ THREE PLACE DECIMAL $\pm .005$	NAME	DATE	SEASTROM MFG
	DRAWN		
	CHECKED		RETAINING WASHER
	ENG APPR.		
	MFG APPR.		
MATERIAL	COMMENTS:		
ALUMINUM			
FINISH			
SEE NOTE 1			
DRAWING IS NOT TO SCALE			
	SIZE	DWG. NO.	REV.
	A	5759-5	-