

No. HOLES: 1

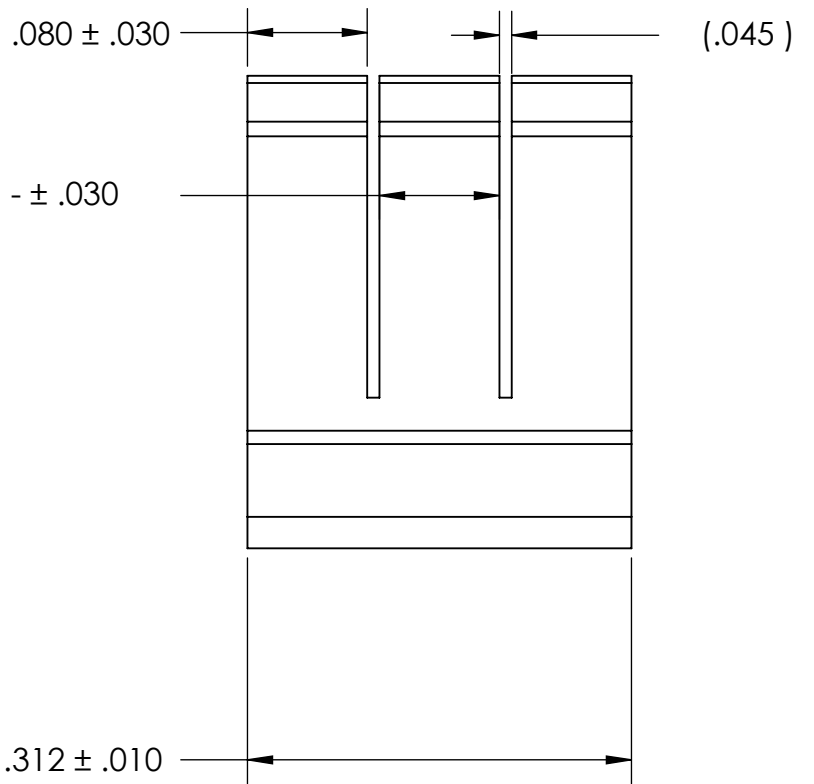

NOTES
1. SPRING STEEL, ANNEALED

2. QUENCH & TEMPER 80-83 HR15N

3. NONE

4. DIMENSIONS ARE TAKEN WITH THE PART CLAMPED TO A FLAT SURFACE AND A DUMMY COMPONENT IN PLACE.

PROPRIETARY AND CONFIDENTIAL
THE INFORMATION CONTAINED IN THIS DRAWING IS THE SOLE PROPERTY OF SEASTROM MANUFACTURING. ANY REPRODUCTION IN PART OR AS A WHOLE WITHOUT THE WRITTEN PERMISSION OF SEASTROM MANUFACTURING IS PROHIBITED.

DIMENSIONS ARE IN INCHES TOLERANCES: FRACTIONAL ± 1/32 ANGULAR: MACH ± 1/2 Deg TWO PLACE DECIMAL ± .01 THREE PLACE DECIMAL ± .005		NAME	DATE	SEASTROM MFG
MATERIAL SEE NOTE 1	HEAT TREAT SEE NOTE 2	DRAWN	CHECKED	
FINISH SEE NOTE 3	COMMENTS:	ENG APPR.	MFG APPR.	SIZE A DWG. NO. 4527-17-31-2 REV. -
DRAWING IS NOT TO SCALE			SHEET 1 OF 1	