

Ø.062 ± .010

Ø.258 ± .005

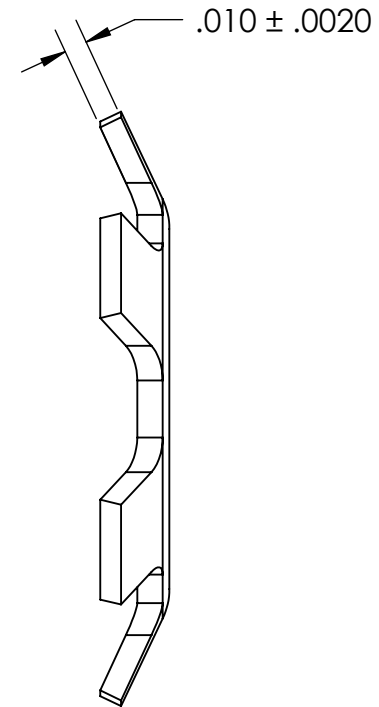
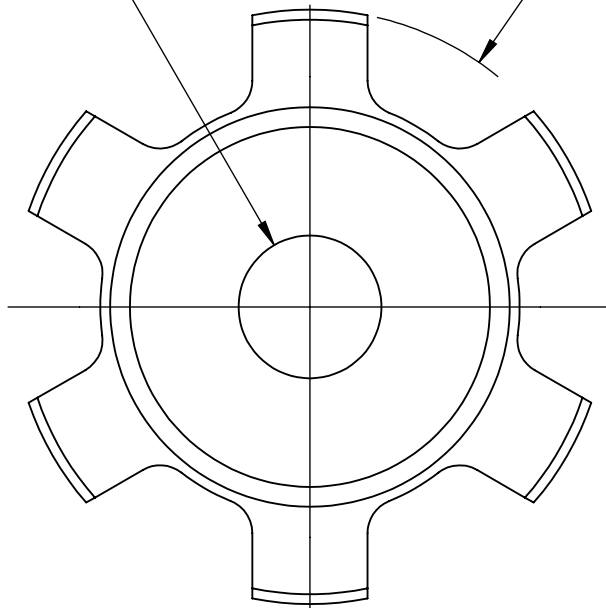

NOTES

1. ZINC PLATE PER ASTM B633, SC1, TYPE III or V, Clear w/Bake
2. HEAT TREAT: 82.5 - 84.5 HR15N
3. No. TABS: 6, EQUALLY SPACED.
4. DESIGN HOLE SIZE: Ø.250 ± .002
5. DIMENSIONS APPLY PRIOR TO PLATING.

PROPRIETARY AND CONFIDENTIAL

THE INFORMATION CONTAINED IN THIS DRAWING IS THE SOLE PROPERTY OF SEASTROM MANUFACTURING. ANY REPRODUCTION IN PART OR AS A WHOLE WITHOUT THE WRITTEN PERMISSION OF SEASTROM MANUFACTURING IS PROHIBITED.

DIMENSIONS ARE IN INCHES TOLERANCES: FRACTIONAL ± 1/32 ANGULAR: MACH ± 1/2 Deg TWO PLACE DECIMAL ± .01 THREE PLACE DECIMAL ± .005	NAME	DATE	SEASTROM MFG RETENTION WASHER
	DRAWN		
	CHECKED		
	ENG APPR.		
	MFG APPR.		
MATERIAL	COMMENTS:		
FINISH			
SEE NOTE 1			
DRAWING IS NOT TO SCALE	SIZE	DWG. NO.	REV.
	A	2715-1	-
			SHEET 1 OF 1