

REFERENCE SEASTROM WORKMANSHIP STD. 8.4.1.W2

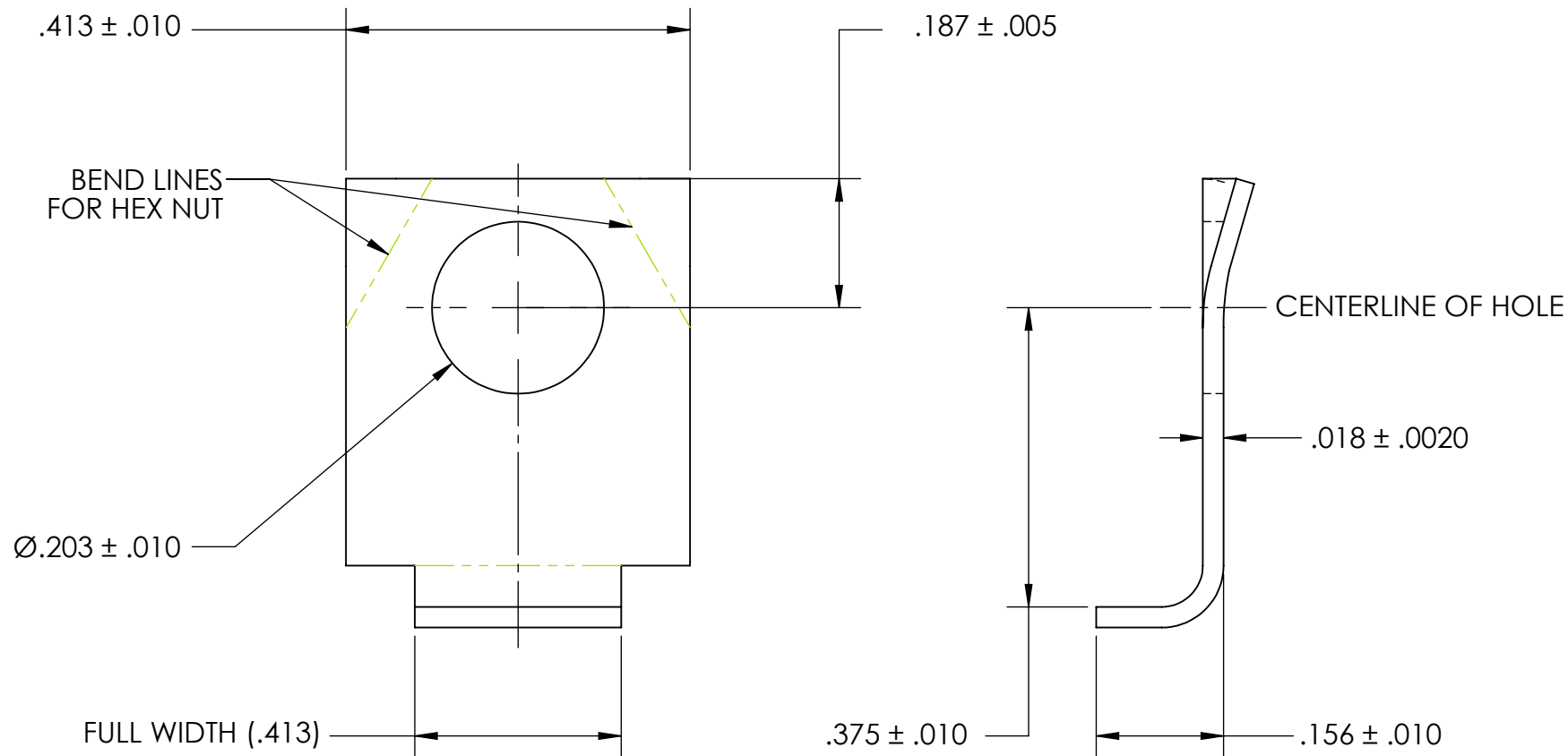

NOTES

1. NONE
2. SCREW SIZE: 10 / M4.5

**PROPRIETARY AND CONFIDENTIAL**  
 THE INFORMATION CONTAINED IN THIS DRAWING IS THE SOLE PROPERTY OF SEASTROM MANUFACTURING. ANY REPRODUCTION IN PART OR AS A WHOLE WITHOUT THE WRITTEN PERMISSION OF SEASTROM MANUFACTURING IS PROHIBITED.

DIMENSIONS ARE IN INCHES TOLERANCES: FRACTIONAL $\pm 1/32$ ANGULAR: MACH $\pm 1/2$ Deg TWO PLACE DECIMAL $\pm .01$ THREE PLACE DECIMAL $\pm .005$	NAME	DATE	SEASTROM MFG  TAB LOCK WASHER
	DRAWN		
	CHECKED		
	ENG APPR.		
	MFG APPR.		
	Q.A.		
MATERIAL	COMMENTS:		SIZE
300 SERIES STAINLESS STEEL			DWG. NO.
FINISH			REV.
SEE NOTE 1			-
DRAWING IS NOT TO SCALE			5749-10-1-2
			SHEET 1 OF 1